



## Overrunning, Indexing, Backstopping Bearing Envelope (62 Series) Design, Sprag Clutches

### CSK..P

CSK..P has the same construction and outside dimensions as type CSK, but has a keyway on the inner race.

These clutches can be mounted on a shaft with recommended k6 tolerance and the outer race must be pressed into a rigid housing with a recommended N6 tolerance. The resulting housing and shaft diameters must be checked to ensure that the bearing has adequate radial clearances.



### CSK..PP

CSK..PP features a keyway on both the inner and outer race. The recommended mounting tolerances are k6 on the shaft and K6 in the rigid housing. A h6 tolerance on the shaft or H6 in the housing are also acceptable for a light press fit assembly. Always check to ensure that the bearing has adequate radial clearances.

Operating temperature range: -4°F (-20°C) to 212°F (+100°C). Peaks up to 248°F (+120°C) are acceptable for short periods. Please contact us for higher temperatures.

### Specifications

Model	Size	Bearing Series	Torque Capacity lb.ft. (Nm)	Max. Overrunning Speed RPM	Resistance after run-in lb.in. (Ncm)	Lubrication	Shipping Weight lb. (kg)
CSK..P/CSK..PP	15	6202	14.7 (20)	8,400	0.79 (0.9)	Grease	0.13 (0.06)
	17	6203	30 (40)	7,350	0.97 (1.1)	Grease	0.15 (0.07)
	20	6204	50 (68)	6,000	1.15 (1.3)	Grease	0.24 (0.11)
	25	6205	77 (105)	5,200	1.77 (2)	Grease	0.31 (0.14)
	30	6206	133 (180)	4,200	3.89 (4.4)	Grease	0.46 (0.21)
	35	6207	177 (240)	3,600	5.13 (5.8)	Grease	0.66 (0.3)
	40	—	284 (385)	3,000	6.20 (7)	Grease	1.10 (0.5)
CSK..P-2RS	20	—	50 (68)	6,000	6.77 (6)	Grease	0.24 (0.11)
	25	—	77 (105)	5,200	6.77 (6)	Grease	0.31 (0.14)
	30	—	133 (180)	4,200	8.46 (7.5)	Grease	0.46 (0.21)

### Typical Mounting Arrangement

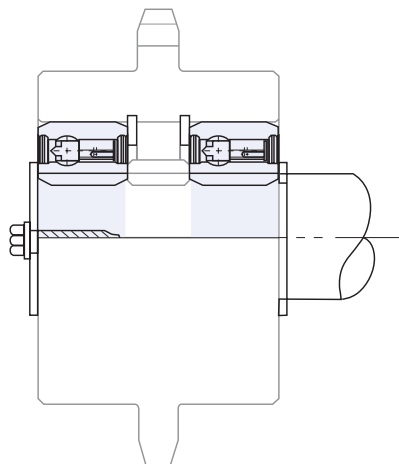

The Model CSK..P clutches must be secured to the shaft by customer supplied snap ring, set collar, spacer, etc. The outer race is secured with a press fit to a N6 tolerance. The Model CSK..PP clutches have a keyseat on both races and must be secured by customer supplied snap ring, set collar, spacer, etc.

**CSK..P**

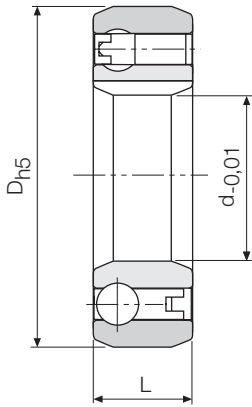

**CSK..PP**

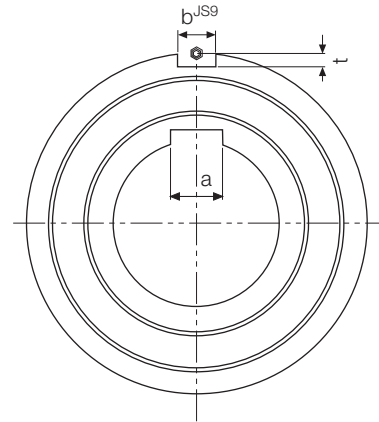
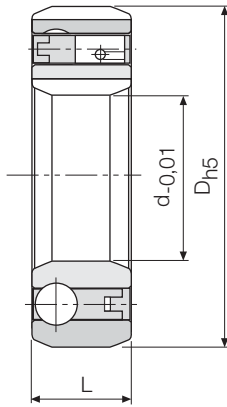

**Dimensions** inches (mm)

Size	D <sub>h5</sub> in. (mm)	L in. (mm)	b in. (mm)	t in. (mm)	Bearing Loads	
					Dynamic lb. (kN)	Static lb. (kN)
15	1.38 (35)	0.43 (11)	.08 (2)	.02 (0.6)	1665 (7.4)	769.5 (3.42)
17	1.57 (40)	0.47 (12)	.08 (2)	.04 (1.0)	1777.5 (7.9)	855 (3.8)
20	1.85 (47)	0.55 (14)	.12 (3)	.06 (1.5)	2115 (9.4)	1003.5 (4.46)
25	2.05 (52)	0.59 (15)	.24 (6)	.08 (2.0)	2407.5 (10.7)	1228.5 (5.46)
30	2.44 (62)	0.63 (16)	.24 (6)	.08 (2.0)	2632.5 (11.7)	1451.25 (6.45)
35	2.83 (72)	0.67 (17)	.31 (8)	.10 (2.5)	2835 (12.6)	1638 (7.28)
40	3.15 (80)	0.87 (22)	.39 (10)	.12 (3.0)	3496.5 (15.54)	2756.25 (12.25)
20	1.85 (47)	0.75 (19)	.12 (3)	.06 (1.5)	2115 (9.4)	1003.5 (4.46)
25	2.04 (52)	0.78 (20)	.24 (6)	.08 (2.0)	2407.5 (10.7)	1228.5 (5.46)
30	2.44 (62)	0.82 (21)	.24 (6)	.08 (2.0)	2632.5 (11.7)	1451.25 (6.45)

**Bore sizes and keyseats** inches (mm)

Size	d Bore Size	a Keyseat*
15	0.59 (15)	(5 X 1.2)
17	0.67 (17)	(6 X 1.6)
20	0.79 (20)	(6 X 1.6)
25	0.98 (25)	(8 X 2)
30	1.18 (30)	(8 X 2)
35	1.38 (35)	(10 X 2.4)
40	1.57 (40)	(12 X 3.3)

\* For keyseat sizes CSK 15–35 use DIN 6885.3.  
For size 40 use DIN 6885.1 table on page 123.